

# Fatigue Crack Propagation in Welded Joint

By V. M. RADHAKRISHNAN

## ABSTRACT

*Welded joints are often subjected to fatigue type of loading which results in the initiation and propagation of a dominant crack. Thus characterization of crack growth behaviour in weld metal, heat affected zone and base metal is very important to evaluate the relative strength of the joint. The crack growth in weld metal is very much dependent on the residual stress pattern and so the fatigue strength of weldment may be inferior or superior to the base metal depending on the location of the defect and type of loading applied. These aspects of the problem are discussed in detail in the present paper.*

## 1. Introduction

Many of the welded structures are subjected to cyclic loading which results in crack initiation and propagation, though the stress may be below the yield strength of the bulk material. Normally the S-N curve and the endurance limit obtained from it will be used for the design of structures subjected to fatigue. However, in the case of welded joints, the situation is somewhat complex, in the sense that welding process by itself might introduce certain defects or stress concentration points from which crack can easily nucleate and propagate bringing in the catastrophic failure of the structure. The crack nucleation and propagation will be very much influenced by the residual stresses introduced in the material due to welding. The base metal, the heat affected zone where structural transformation might have taken place during the welding process and the weldment as such, will have different responses to the cyclic stresses in terms of crack initiation and propagation. In the following, the problems associated in characterizing the crack growth in welded joints and evaluating the life of the structure are discussed.

## 2. Representation of crack growth data

Crack growth investigations are normally carried out in the three zones, i.e., base metal, HAZ and weld metal, in order to evaluate the relative strength and response of the material. The specimens used are of (a) compact tension type with the notch on one side of the specimen and (b) centre notch type where the initial notch will be at the centre of the specimen. The length 'a' of the crack initiating and propagating from the root of the notch, is measured by a travelling microscope or by electrical method. The rate of propagation,  $da/dN$ , is plotted against the stress intensity factor range  $\partial K (= \phi \partial \sigma \sqrt{a})$  which is a function of the applied stress range  $n\sigma$  and the instantaneous value of the crack length 'a'.  $\phi$  is a geometry constant. A typical crack growth rate curve is schematically shown in Fig. 1, which shows three stages. In stage I, the crack propagation is quite rapid which is normally in the range of  $10^{-8}$  mm/cycle to  $10^{-6}$  mm/cycle for steels. When the propagation enters stage II, the slope of the curve changes and here the Paris-Erdogan<sup>1</sup> equation

$$\frac{da}{dN} = C (\partial K)^n \quad (1)$$

appears to be mostly obeyed. C and n are material constants. This stage II ranges from  $10^{-6}$  mm/cycle

\*Dr. Radhakrishnan was with DMRL, Hyderabad at the time of writing this paper. He is now with the Metallurgy Deptt., I.I.T., Madras.

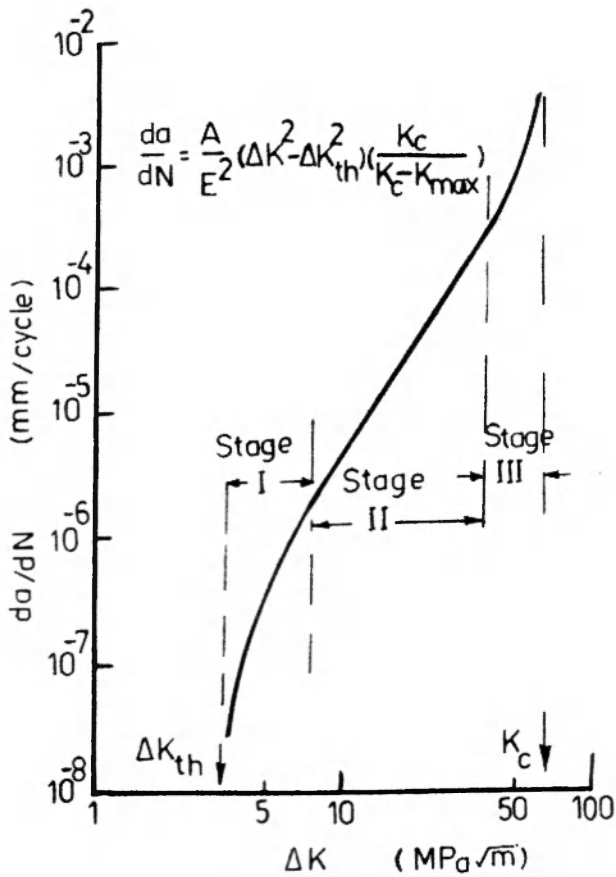

Fig. 1. Schematic diagram of fatigue crack growth rate curve.

to around  $10^{-3}$  mm/cycle. Beyond this crack growth rate, stage III sets in when the growth will be very fast and catastrophic failure will soon be brought in. The entire sigmoidal type crack growth rate curve can be described by<sup>2,3</sup>

$$\frac{da}{dN} = \frac{A}{E^2} (\partial K^2 - \partial K_{th}^2) \left( \frac{K_c}{K_c - K_{max}} \right) \quad (2)$$

where  $\partial K_{th}$  is the threshold stress intensity factor corresponding to  $10^{-8}$  mm/cycle and  $K_c$  the critical stress intensity factor for sudden fracture of that particular specimen size.

The crack propagation characteristics of the weld metal must be the same as the base metal. However due to different variables introduced during welding such as welding defect, residual stresses, etc., the fatigue behaviour of weld metal, HAZ and base metal will be different from each other. In the next section, some typical fatigue crack growth data published recently<sup>4, 5, 6</sup> are discussed in detail.

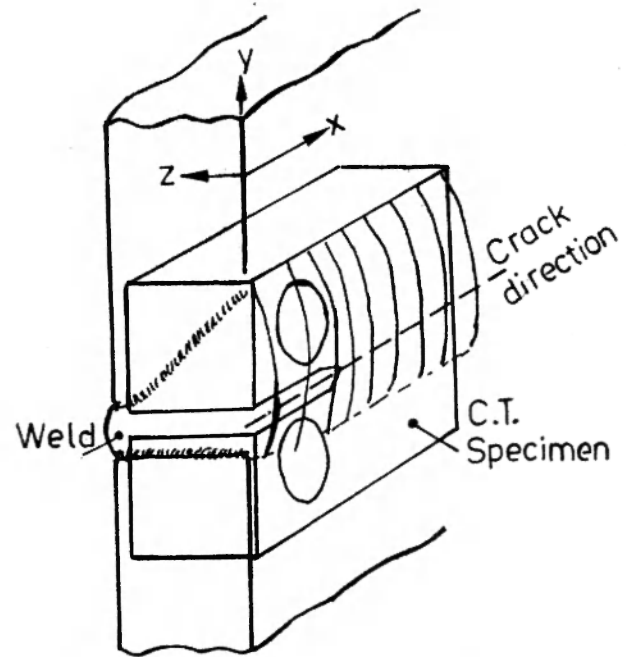

Sampling of L.T. specimen

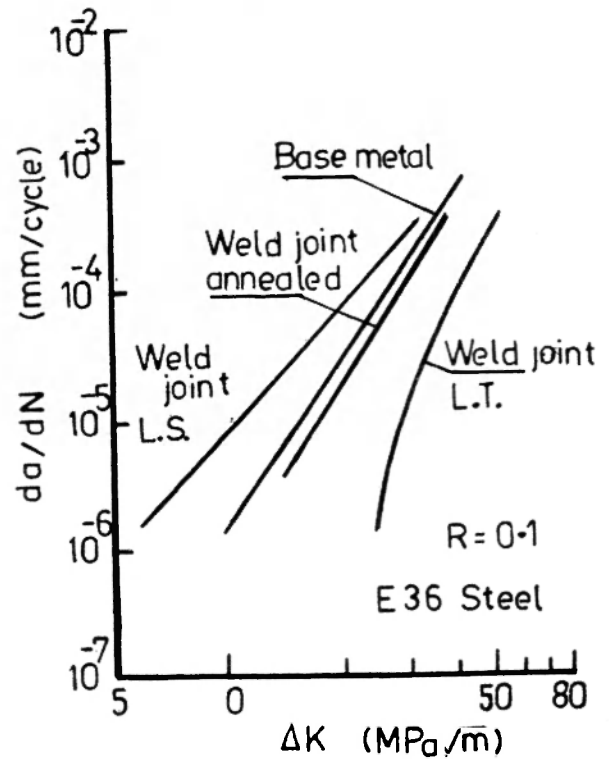

Fig. 2. Crack growth rate curves for E 36 steel.

### 3. Data analysis

The fatigue crack growth data of E 36 steel<sup>4</sup> have been replotted and shown in Fig. 2. The chemical

composition and mechanical properties of the material are given in Table I. The specimen is of C.T. type and the crack propagation was in the heat affected zone. Two orientations of the specimen were analysed, one in the transverse direction (L.T.) as indicated in the figure and the second one in the L.S. direction, in which the thickness of the weld plate becomes the width of the specimen and the crack propagation is in the Z-direction. In addition to the above, two weld joint specimens, base metal and weld joint in the annealed condition were also tested for crack growth and the relation between  $da/dN$  vs  $\partial K$  plotted. It can be seen that crack growth rate  $da/dN$  is much lower for L.T. specimen than for base metal or annealed joint. Crack growth rate for L.S. specimens is higher than that of base metal. These results clearly indicate that L.T. direction is stronger in fatigue than either the base metal/annealed joint or the L.S. direction.

Another material investigated<sup>5</sup> is Czechoslovak steel 16224.6 (for composition and mechanical properties see Table I). The welded joints were prepared using manual arc welding technology. The specimens were of C.T. type with crack propagating in the transverse

direction (L.T.) along the weld metal. In addition, base metal as well as joints in the annealed condition were also tested and the relation between  $da/dN$  and  $\partial K$  is shown in Fig. 3, for these different specimens. It can be seen that weld joint tested for crack growth in the L.T. direction showed a crack growth rate much lower than that for base metal or annealed joint—a trend similar to what has been observed with E 36 steel in the first example.

A third example is a high strength steel HT 80 (see Table I), which has been welded by different processes such as manual arc welding, gas metal arc welding, and submerged arc welding. Crack propagation tests were carried out on base metal, weld metal and HAZ<sup>6</sup>. The specimen used was a central notch type as shown in Fig. 4, and the crack propagation direction was in the L.T. The relation between  $da/dN$  and  $\partial K$  is shown in Fig. 5, typically for two welding processes, namely, manual arc welding and submerged arc welding. The growth rate covers a wide range from  $10^{-8}$  mm/cycle upto  $10^{-2}$  mm/cycle. It can be seen that the crack growth rate in the base metal is lower than that in the weld metal or in the HAZ in both cases of welding processes.

TABLE I

**Chemical Composition**

Material	C	Mn	Si	Mo	Ni	W	Al	N <sub>2</sub>	Cr	V	B
E 36	0.145	1.4	0.3	0.031	0.42	0.075	0.02	0.002	—	—	—
Steel 16224.6	0.18	0.86	0.27	0.35	0.85	—	—	—	0.94	—	—
HT 80	0.12	0.85	0.32	0.41	0.8	—	0.056	—	0.48	0.04	0.0007

**Mechanical Properties (Base Metal)**

Material	Yield strength MPa	Ultimate strength MPa	Percentage elongation
E 36	375	545	—
Steel 16224.6	796	885	14
HT 80	784	824	31

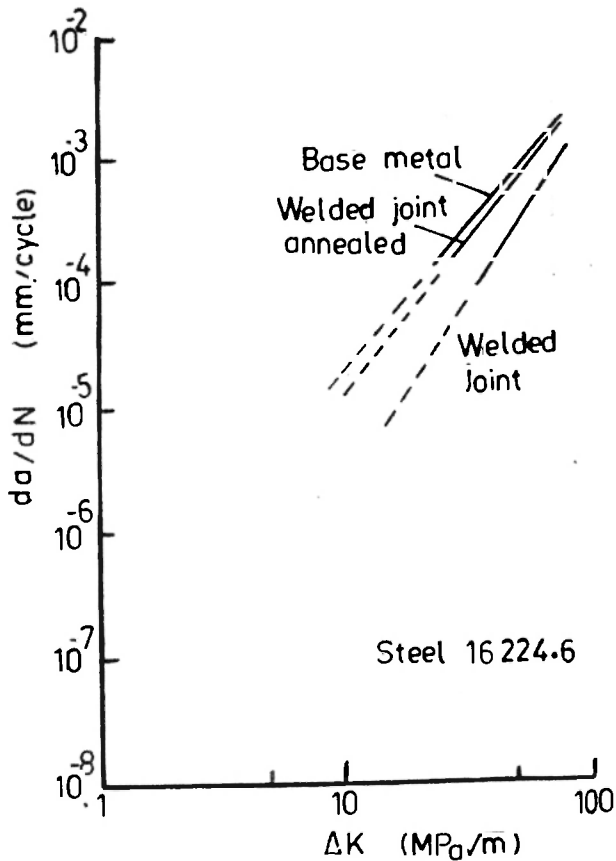

Fig. 3. Crack growth rate curves for steel 16224.6.

This difference is much more pronounced in stage I of crack propagation at low values of  $\partial K$ . The results show that in these cases the fatigue strength of weld metal or HAZ is worse than the base metal.

A study of these data from three different investigations shows a somewhat confusing picture in the sense that the weld metal is either superior or inferior to the base metal from the fatigue crack growth point of view. In the following section is discussed the possible reason for this seemingly different behaviour and how to evaluate the fatigue behaviour of the welded joint.

**4. Discussion**

As has been pointed out earlier, residual stresses developed during welding play a very important role in controlling the crack propagation behaviour. As a matter of fact, annealed welded joints, as in example (1) and (2) have the same crack propagation rates as the base metal, since annealing process will relieve the residual stresses. But in other cases, the crack growth will be governed by the type of residual stresses present

in the direction perpendicular to crack propagation plane.

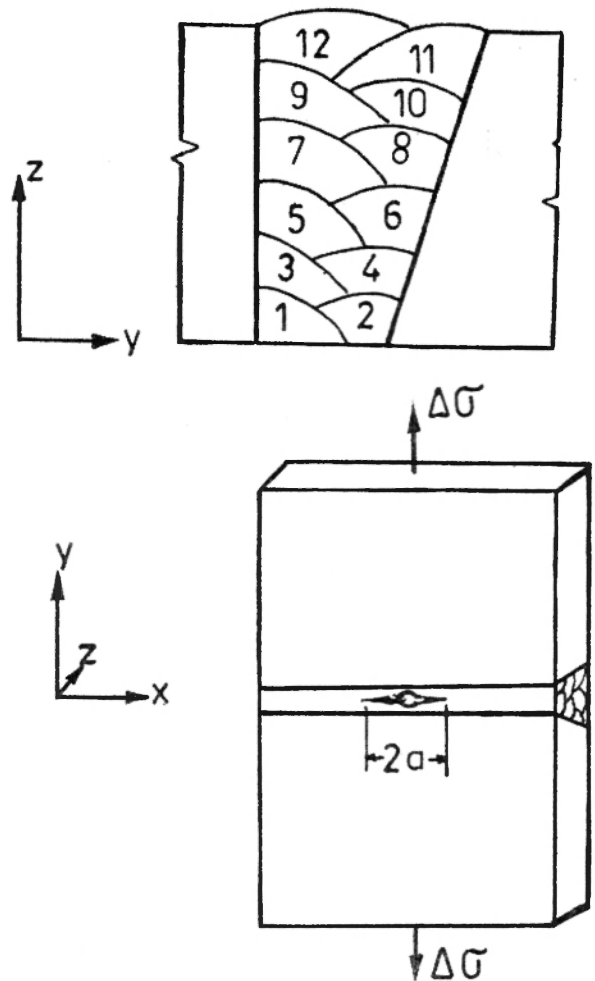

Fig. 4. Specimen used for HT 80 steel.

Fig. 6. shows a schematic diagram of the residual stresses that will develop in a simple butt welded joint. In the X-direction (transverse) perpendicular to YZ-plane, the weld metal and the HAZ will have a tensile residual stress  $\sigma_x$  and in the base metal, away from the weld, a compressive residual stress will be present. In the Y-direction (longitudinal) perpendicular to XZ plane, the residual stress  $\sigma_y$  will be such that in the mid region it will be tensile and at the edge compressive. For the crack propagation in the transverse direction (X-direction) the residual stress  $\sigma_y$  will govern the growth. In a compact tension type of specimen with edge notch, the material just ahead of the notch will have a compressive residual stress as indicated in Fig. 6, and as shown in Fig. 7, as measured values. The compressive residual stress will decrease the effective stress intensity factor, thereby reducing the crack growth rate. As the crack length increases, the pattern of the

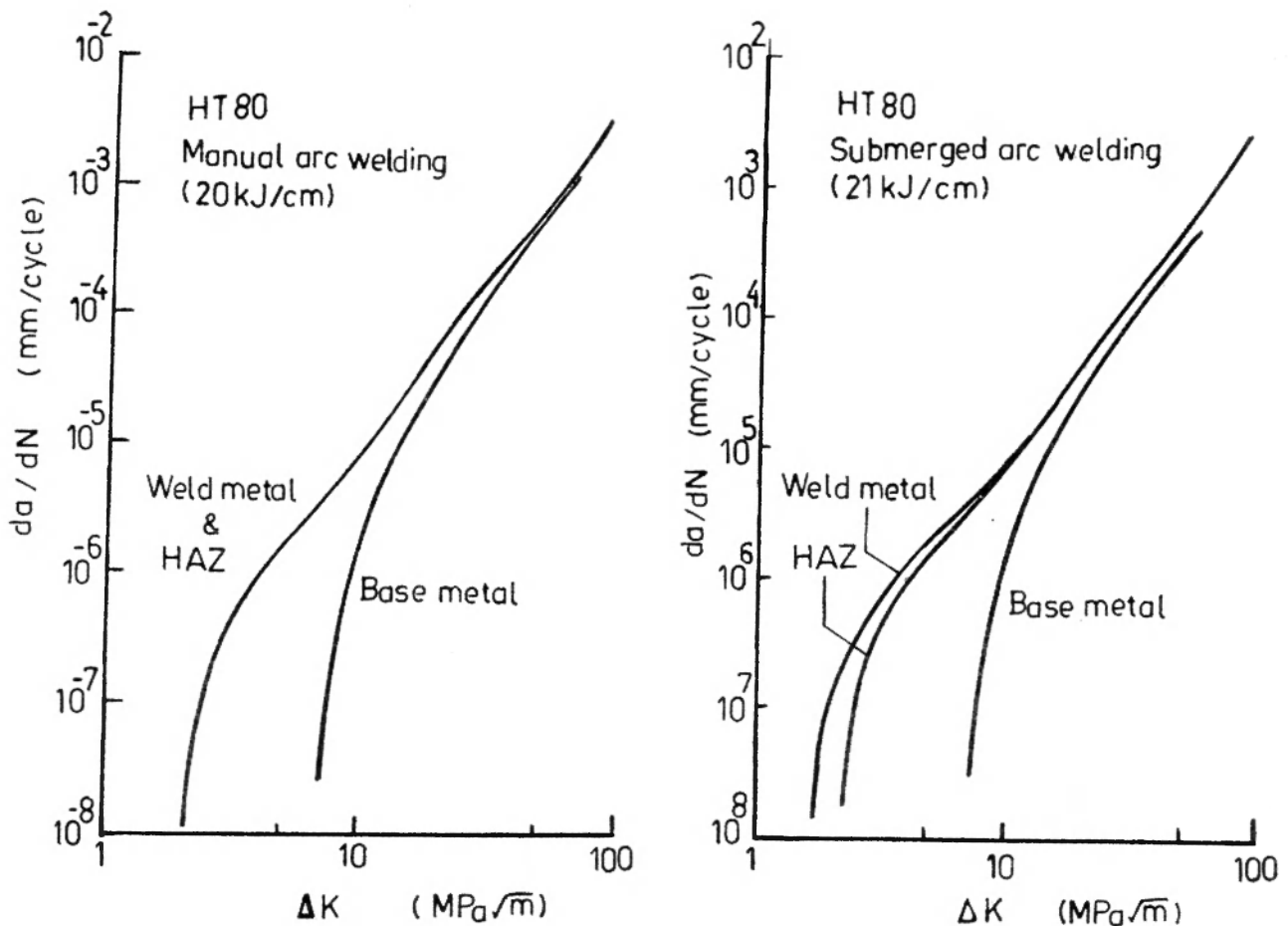

Fig. 5. Crack growth rate curve for HT 80.

residual stress will remain the same, but its magnitude will reduce. So, as the crack advances further, and comes to the stage II, the effect of residual stress will become small. As a result, the crack growth rate curve will try to merge with that of the base metal or the annealed joint. This is the main reason for the lower crack growth rates observed in examples (1) and (2) where the specimens were of C.T. type and the crack growth was in the transverse X-direction. In example (3) the crack growth is in the transverse direction but the specimen is of central notch type. So, as indicated in Fig. 6, the  $\sigma_y$  residual stress at the notch tip zone will be tensile in nature, as a result of which the crack growth rate will be faster. This is what is observed in Fig. 5.

In the L.S. direction (Z-direction) the crack growth rate is higher than the base metal, as has been observed

in E 36 steel (Fig. 2). Here again the tensile residual stress  $\sigma_y$  perpendicular to the XZ plane is responsible for the higher crack growth rate.

##### 5. Concluding remarks

The above analysis clearly shows that a defect or a stress concentration point which may be accidentally introduced during the welding process, will have fatigue crack propagation properties depending on the residual stress pattern around the region. The weldment may be better or worse than the base material in fatigue strength, depending on whether compressive or tensile residual stress is present in the zone near the defect. The best way to avoid poor resistance in fatigue of the weld metal is to anneal the joint so that the crack propagation properties of the weld will be the same as that of the base metal.

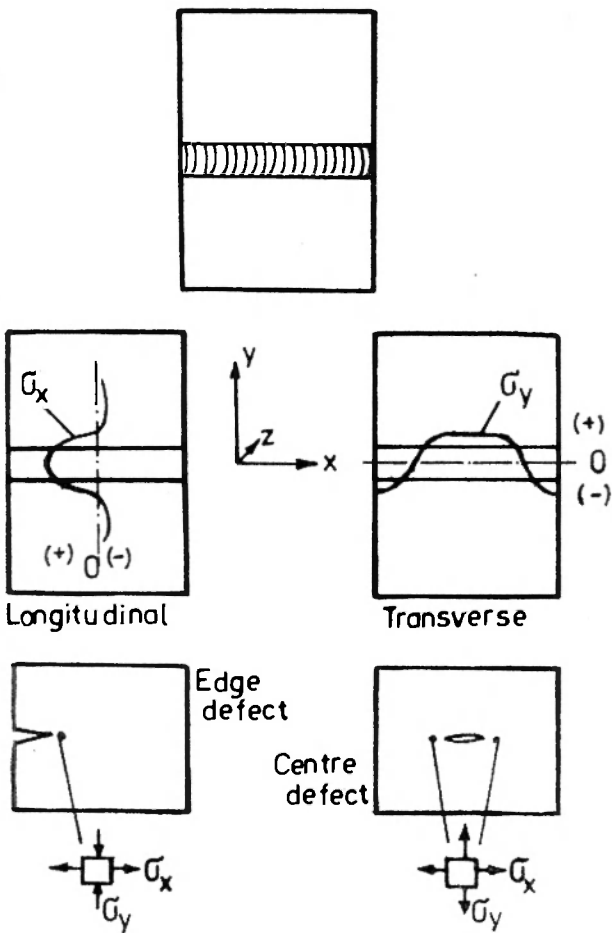

Fig. 6. Schematic diagram of residual stresses developed during butt welding.

References

1. Paris, P.C. and Erdogan, F. : Trans. A.S.M.E., J. Basic Engg., 85 (1963) 528.

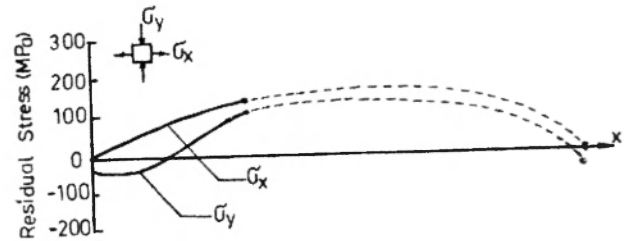
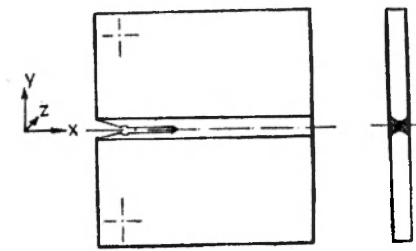

Fig. 7. Typical residual stress distributions in actual weld joints.

2. McEvily, A.J. : J Met Sci., 11 (1977) 274.  
 3. Radhakrishnan, V.M. : Trans. I.I.M., 36 (1983) 37.  
 4. Truchon, M., Lieurade, H.P. and Putot, C. : Inter Conf on Offshore Structures (Oct 1981) Paper No. 816. I.I.W. Document No. XIII-1056-82.  
 5. Koloman, U. : I.I.W. Document No. XIII-1094-83 (April 1983).  
 6. Ohta, A. et al. : I.I.W. Document No. XIII-1077-83 (Dec 1982).